DF-78

CONTENTS

1-1 Specifications	
1-1-1 Specifications	1-1-1
1-1-2 Part names	1-1-2
1-1-3 Machine cross section	1-1-3
1-1-4 Drive system	1-1-4
1-2 Installation	
1-2-1 Unpacking	1-2-1
1-3 Troubleshooting	
1-3-1 Paper misfeed detection	1-3-1
(1) Paper misfeed indication	1-3-1
(2) Paper misfeed detection condition	1-3-2
(3) Paper misfeeds	1-3-3
1-3-2 Self-diagnosis	1-3-4
(1) Self-diagnostic function	1-3-4
(2) Self-diagnostic codes	1-3-4
1-3-3 Electrical problems	1-3-7
(1) The paper conveying motor does not operate.	1-3-7
(2) The feedshift solenoid does not operate.	1-3-7
(3) The pickup solenoid does not operate.	1-3-7
(4) The front side registration motor does not operate.	1-3-7
(5) The rear side registration motor does not operate.	1-3-7
(6) The trailing edge registration motor does not operate.	1-3-7
(7) The cooling fan motor does not operate.	1-3-8
1-3-4 Mechanical problems	1-3-9
(1) Paper jams.	1-3-9
(2) Abnormal noise is heard.	1-3-9
1-4 Assembly and Disassembly	
1-4-1 Precautions for assembly and disassembly	1-4-1
(1) Precautions	1-4-1
(2) Adjusting the positions of the front side registration cursor, rear side registration cursor and trailing edge registration cursor (reference)	1-4-2
(3) Cleaning the stapler	1-4-3
(4) Adjusting the pressure of curl eliminator mechanism	1-4-4
2-1 Mechanical construction	
2-1-1 Construction of each section	2-1-1
(1) Paper conveying operation in sort mode	2-1-2
2-1-2 Intermediate tray section	2-1-3
(1) Paper registration on the intermediate tray	2-1-4
2-1-3 Stapler section	2-1-5
2-2 Electrical Parts Layout	
2-2-1 Electrical parts layout	2-2-1
(1) Paper conveying section	2-2-1
(2) Intermediate tray section	2-2-2
(3) Stapler section	2-2-3
2-3 Operation of the PCBs	
2-3-1 Main PCB	2-3-1
2-4 Appendixes	
Timing chart No. 1	2-4-1
Timing chart No. 2	2-4-2
Timing chart No. 3	2-4-3
Periodic maintenance procedure	2-4-4
Wiring diagram	2-4-5

1-1-1 Specifications

Type Built-in
Number of trays 1 (intermediate tray)
Stapling limit A4/11" x 8¹/₂" or smaller: 30 sheets
Other sizes than above: 20 sheets
Power source Electrically connected to the copier
Weight Approximately 11 kg/24.2 lbs

1-1-2 Part names

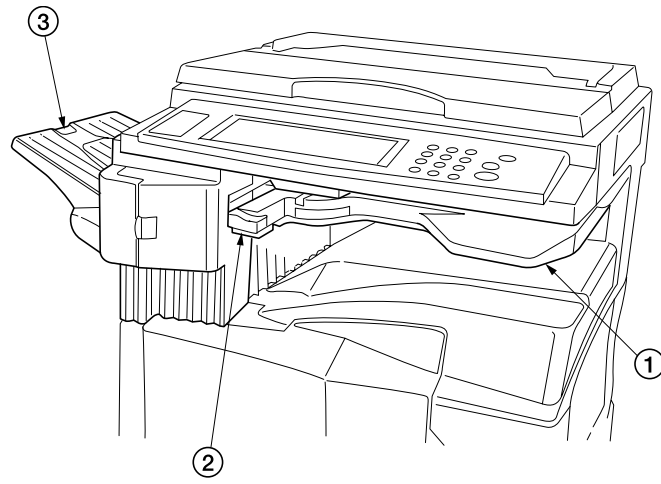

Figure 1-1-1

- ① Intermediate tray
- ② JAM release lever
- ③ Eject tray

1-1-3 Machine cross section

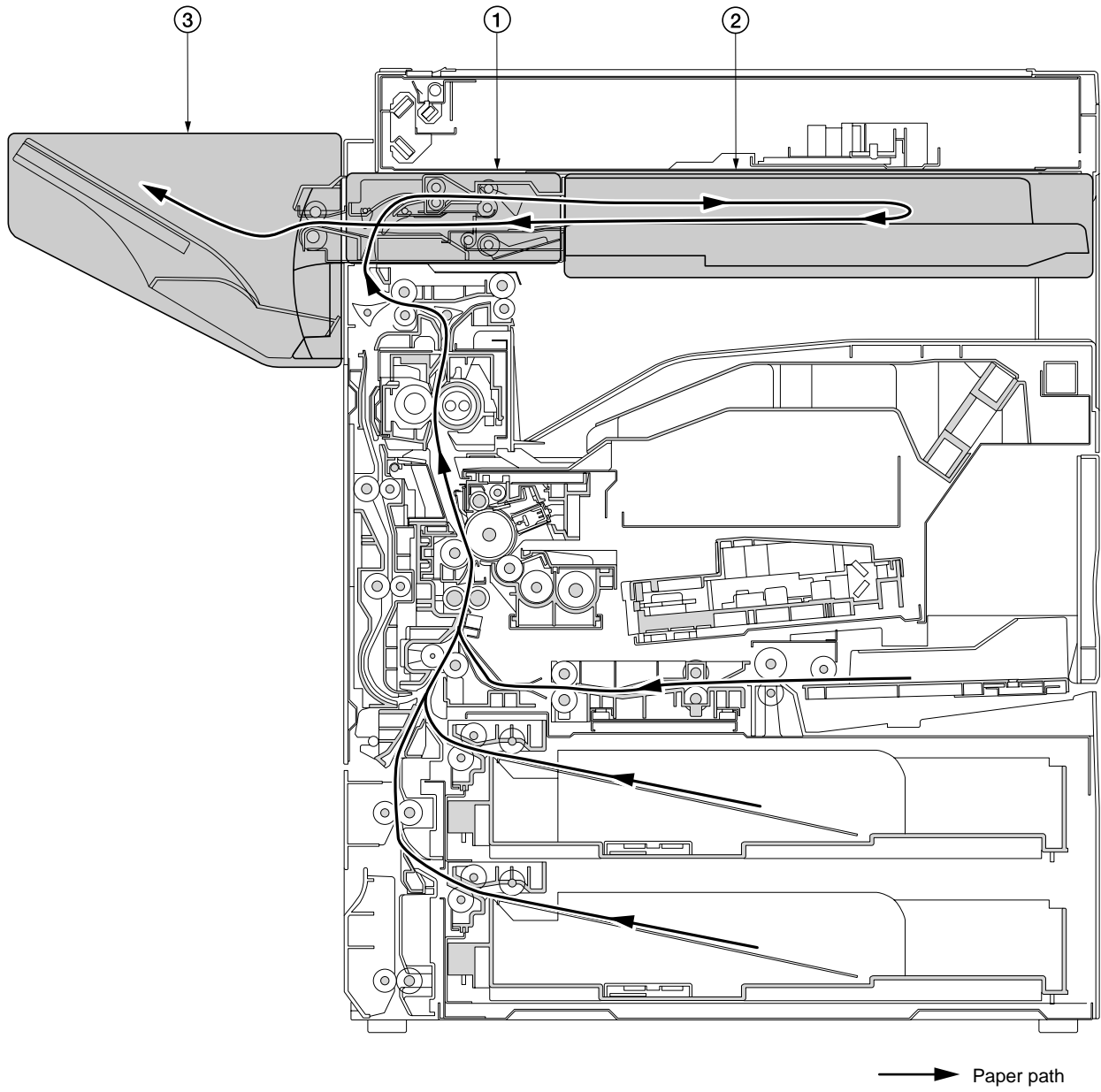

Figure 1-1-2 Machine cross section

- ① Paper conveying section
- ② Intermediate tray section
- ③ Eject section

1-1-4 Drive system

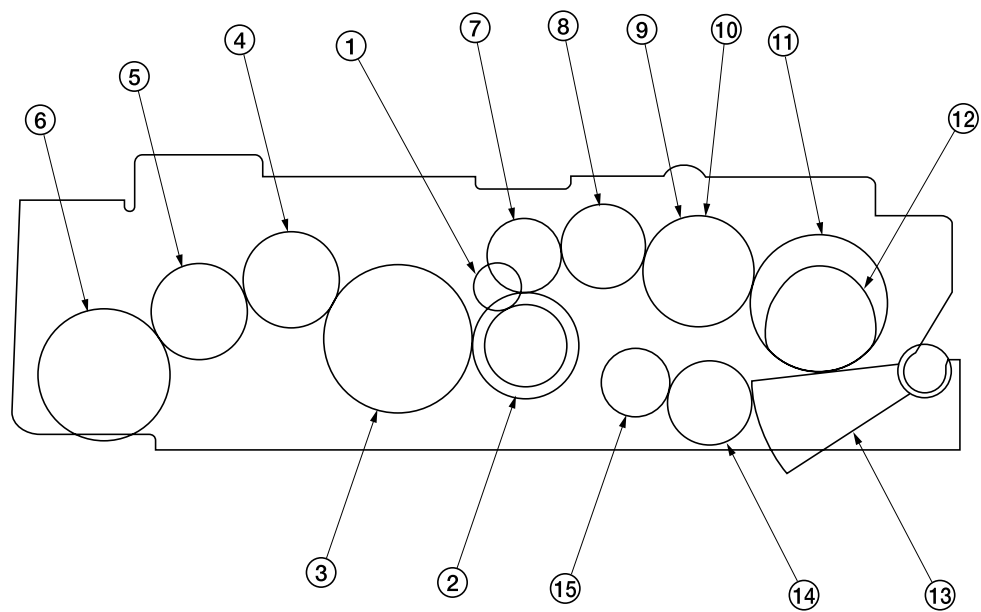

Figure 1-1-3

- | | |
|------------------------------|----------------|
| ① Paper conveying motor gear | ⑨ Central gear |
| ② Gear 31/20 | ⑩ Gear 21 |
| ③ Gear 28 | ⑪ Gear 26 |
| ④ Gear 18 | ⑫ Clutch cam |
| ⑤ Gear 18 | ⑬ Stopper gear |
| ⑥ Gear 25 | ⑭ Gear 32 |
| ⑦ Gear 14 | ⑮ Gear 26 |
| ⑧ Gear 16 | |

1-2-1 Unpacking

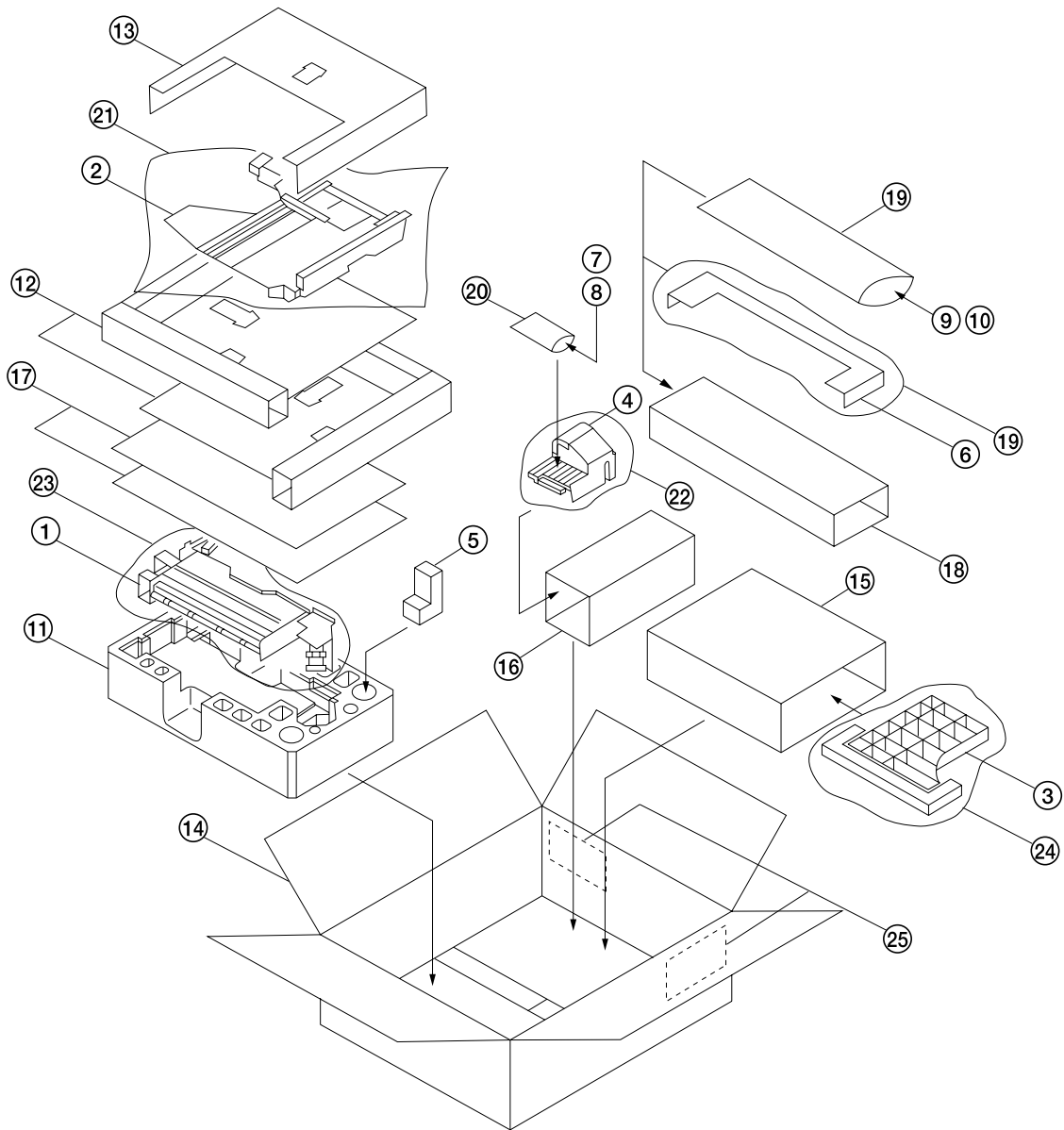

Figure 1-2-1 Unpacking

- | | |
|-------------------------------------------------|-------------------|
| ① Paper conveying unit | ⑭ Outer case |
| ② Intermediate tray unit | ⑮ Spacer 1 |
| ③ Eject tray | ⑯ Spacer 2 |
| ④ Stapler cover | ⑰ Spacer 3 |
| ⑤ Staple cartridge | ⑱ Spacer 4 |
| ⑥ Large eject cover | ⑲ Plastic bag |
| ⑦ Cross-head chrome TP-A screws M3 × 05 | ⑳ Plastic bag |
| ⑧ Cross-head bronze binding TP-A screws M3 × 05 | ㉑ Plastic sheet |
| ⑨ Front eject cover | ㉒ Plastic bag |
| ⑩ Rear eject cover | ㉓ Plastic bag |
| ⑪ Paper conveying unit pad | ㉔ Air-padded bag |
| ⑫ Upper intermediate tray pad | ㉕ Bar-code labels |
| ⑬ Lower intermediate tray pad | |

1-3-1 Paper misfeed detection

(1) Paper misfeed indication

When paper jams, the machine immediately stops operation and the occurrence of a paper jam is indicated on the copier operation panel.

To remove the jammed paper, lower the intermediate tray.

To reset the paper misfeed detection, detach and refit the intermediate tray to turn the tray open/close switch off and on.

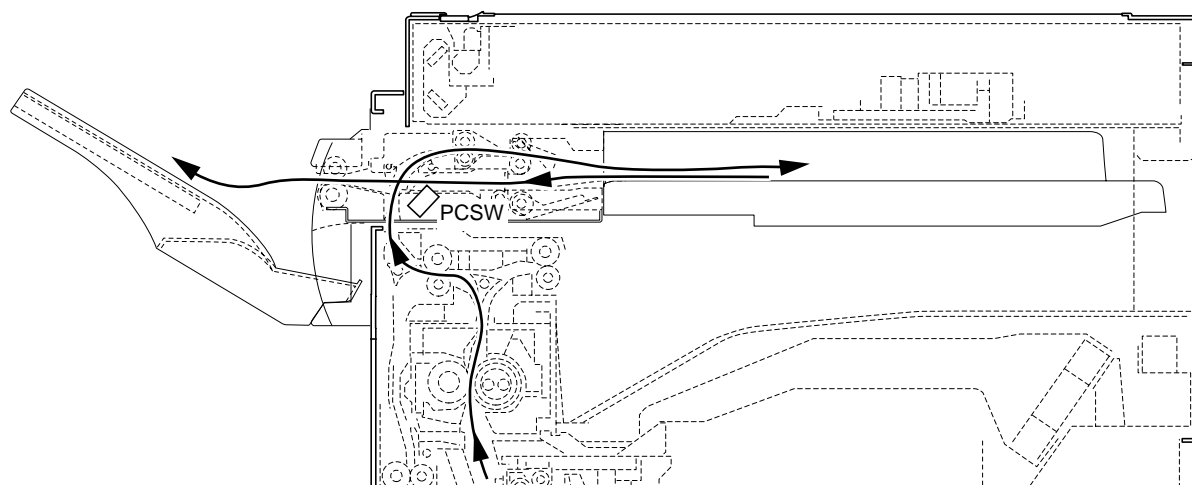
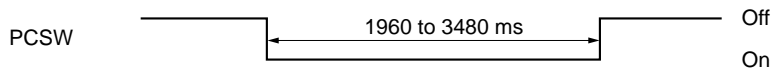

Figure 1-3-1 Paper misfeed detection

(2) Paper misfeed detection condition

- Jam between the finisher and copier (jam code 81)
The paper conveying switch does not turn on within 1550 ms of the signal requesting paper ejection is output from the copier.
- Intake jam (jam code 82)
During paper intake from the copier, the paper conveying switch (PCSW) does not turn off within 1960 to 3480 ms (depending on paper size) of paper conveying switch (PCSW) turning on.



Timing chart 1-3-1

- Jam during paper conveying for batch ejection 1 (jam code 83)
When ejection a stack of paper, the paper conveying switch (PCSW) does not turn on within 1590 ms of the paper conveying motor (PCM) turning on.

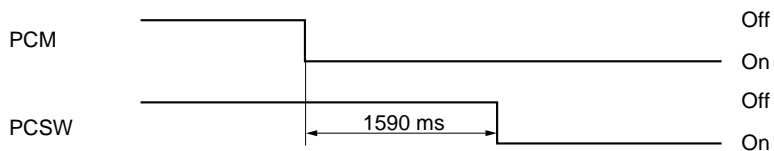

Timing chart 1-3-2

- Jam during paper conveying for batch ejection 2 (jam code 84)
When ejection a stack of paper, the paper conveying switch (PCSW) does not turn off within 2260 to 3190 ms (depending on the paper size) of the paper conveying motor (PCM) turning on.

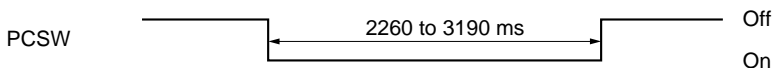

Timing chart 1-3-3

(3) Paper misfeeds

Problem	Causes	Check procedures/corrective measures
(1) Paper jams in the finisher when the main switch is turned on.	A piece of paper torn from copy paper is caught around the paper conveying switch.	Remove any found.
	Defective paper conveying switch.	With 5 V DC present at CN4-9 on the main PCB, check if CN4-10 on the main PCB remains low when the paper conveying switch is turned on and off. If it does, replace the paper conveying switch.
(2) Paper jams in the finisher during copying (intake jam). Jam code 82	Defective paper conveying switch.	With 5 V DC present at CN4-9 on the main PCB, check if CN4-10 on the main PCB remains high or low when the paper conveying switch is turned on and off. If it does, replace the paper conveying switch.
	Check if the feedshift roller or feedshift pulley is deformed.	Check visually and replace the pulley or roller if deformed.
(3) Paper jams in the finisher during copying (jam during paper conveying for batch ejection 1). Jam code 83	Defective paper conveying switch.	With 5 V DC present at CN4-9 on the main PCB, check if CN4-10 on the main PCB remains high or low when the paper conveying switch is turned on and off. If it does, replace the paper conveying switch.
	Check if the feedshift roller or press roller is deformed.	Check visually and replace the pulley or roller if deformed.
(4) Paper jams in the finisher during copying (jam during paper conveying for batch ejection 2). Jam code 84	Defective paper conveying switch.	With 5 V DC present at CN4-9 on the main PCB, check if CN4-10 on the main PCB remains high or low when the paper conveying switch is turned on and off. If it does, replace the paper conveying switch.
	Check if the eject roller or eject pulley is deformed.	Check visually and replace the pulley or roller if deformed.

1-3-2 Self-diagnosis

(1) Self-diagnostic function

This unit is equipped with a self-diagnostic function. When a problem is detected, copying is disabled and the problem displayed as a code consisting of "C" followed by a number between 0440 and 8220, indicating the nature of the problem. A message is also displayed requesting the user to call for service.

After removing the problem, the self-diagnostic function can be reset by turning the tray open/close switch or copier safety switch 1 or 2 off and back on.

(2) Self-diagnostic codes

Code	Contents	Remarks	
		Causes	Check procedure/corrective measures
C0440	Finisher communication problem An error code from the side deck is detected eight times in succession. No communication: there is no reply after 3 retries. Abnormal communication: a communication error (parity or checksum error) is detected five times in succession.	Poor contact in the connector terminals.	Check the connection of connectors CN4, CN5 on the copier main PCB and CN2 on the finisher main PCB, and the continuity across the connector terminals. Repair or replace if necessary.
		Defective copier main PCB.	Replace the copier main PCB and check for correct operation.
		Defective finisher main PCB.	Replace the finisher main PCB and check for correct operation.
C8170	Finisher front side registration motor problem If the front side registration home position sensor is on in initialization, the sensor does not turn off within 570 ms of starting initialization. If the front side registration home position sensor is off in initialization, the sensor does not turn on within 3180 ms of starting initialization.	The front side registration motor connector makes poor contact.	Reinsert the connector. Also check for continuity within the connector cable. If none, remedy or replace the cable.
		The front side registration motor malfunctions.	Replace the front side registration motor and check for correct operation.
		The front side registration home position sensor connector makes poor contact.	Reinsert the connector. Also check for continuity within the connector cable. If none, remedy or replace the cable.
		The front side registration home position sensor malfunctions.	Replace the front side registration home position sensor and check for correct operation.
		Defective finisher main PCB.	Replace the finisher main PCB and check for correct operation.
C8180	Finisher rear side registration motor problem If the rear side registration home position sensor is on in initialization, the sensor does not turn off within 570 ms of starting initialization. If the rear side registration home position sensor is off in initialization, the sensor does not turn on within 2880 ms of starting initialization.	The rear side registration motor connector makes poor contact.	Reinsert the connector. Also check for continuity within the connector cable. If none, remedy or replace the cable.
		The rear side registration motor malfunctions.	Replace the rear side registration motor and check for correct operation.
		The rear side registration home position sensor connector makes poor contact.	Reinsert the connector. Also check for continuity within the connector cable. If none, remedy or replace the cable.
		The rear side registration home position sensor malfunctions.	Replace the rear side registration home position sensor and check for correct operation.

Code	Contents	Remarks	
		Causes	Check procedure/corrective measures
C8180	<p>Finisher rear side registration motor problem</p> <p>If the rear side registration home position sensor is on in initialization, the sensor does not turn off within 570 ms of starting initialization.</p> <p>If the rear side registration home position sensor is off in initialization, the sensor does not turn on within 2880 ms of starting initialization.</p>	Defective finisher main PCB.	Replace the finisher main PCB and check for correct operation.
C8190	<p>Finisher trailing edge registration motor problem</p> <p>If the trailing edge registration home position sensor is on in initialization, the sensor does not turn off within 570 ms of starting initialization.</p> <p>If the trailing edge registration home position sensor is off in initialization, the sensor does not turn on within 4550 ms of starting initialization.</p>	The trailing edge registration motor connector makes poor contact.	Reinsert the connector. Also check for continuity within the connector cable. If none, remedy or replace the cable.
		The trailing edge registration motor malfunctions.	Replace the trailing edge registration motor and check for correct operation.
		The trailing edge registration home position sensor connector makes poor contact.	Reinsert the connector. Also check for continuity within the connector cable. If none, remedy or replace the cable.
		The trailing edge registration home position sensor malfunctions.	Replace the trailing edge registration home position sensor and check for correct operation.
		Defective finisher main PCB.	Replace the finisher main PCB and check for correct operation.
C8210	<p>Finisher front stapler problem</p> <p>The front stapler home position sensor does not change state from non-detection to detection within 200 ms of the start of front stapler motor counterclockwise (forward) rotation. During initialization, the front stapler home position sensor does not change state from non-detection to detection within 600 ms of the start of front stapler motor clockwise (reverse) rotation.</p>	The front stapler connector makes poor contact.	Reinsert the connector. Also check for continuity within the connector cable. If none, remedy or replace the cable.
		The front stapler malfunctions. a) The front stapler is blocked with a staple. b) The front stapler is broken.	a) Remove the front stapler cartridge, and check the cartridge and the stapling section of the stapler. b) Replace the front stapler and check for correct operation.
		Defective finisher main PCB.	Replace the finisher main PCB and check for correct operation.

Code	Contents	Remarks	
		Causes	Check procedure/corrective measures
C8220	<p>Finisher rear stapler problem The rear stapler home position sensor does not change state from non-detection to detection within 200 ms of the start of rear stapler motor counterclockwise (forward) rotation. During initialization, the rear stapler home position sensor does not change state from non-detection to detection within 600 ms of the start of rear stapler motor clockwise (reverse) rotation.</p>	The rear stapler connector makes poor contact.	Reinsert the connector. Also check for continuity within the connector cable. If none, remedy or replace the cable.
		The rear stapler malfunctions. a) The rear stapler is blocked with a staple. b) The rear stapler is broken.	a) Remove the front stapler cartridge, and check the cartridge and the stapling section of the stapler. b) Replace the front stapler and check for correct operation.
		Defective finisher main PCB.	Replace the finisher main PCB and check for correct operation.

1-3-3 Electrical problems

Problem	Causes	Check procedures/corrective measures
(1) The paper conveying motor does not operate.	Broken paper conveying motor coil.	Check for continuity across the coil. If none, replace the paper conveying motor.
	Poor contact of the paper conveying motor connector terminals.	Reinsert the connector. Also check for continuity within the connector cable. If none, remedy or replace the cable.
	Defective finisher main PCB.	Check if a motor drive coil energization signal is output at CN9-9, CN9-10, CN9-11 and CN9-12 on the finisher main PCB. If not, replace the finisher main PCB.
(2) The feedshift solenoid does not operate.	Broken feedshift solenoid coil.	Check for continuity across the coil. If none, replace the feedshift solenoid.
	Poor contact of the feedshift solenoid connector terminals.	Reinsert the connector. Also check for continuity within the connector cable. If none, remedy or replace the cable.
	Defective finisher main PCB.	Check if CN4-2 and CN4-4 on the finisher main PCB go low. If not, replace the finisher main PCB.
(3) The pickup solenoid does not operate.	Broken pickup solenoid coil.	Check for continuity across the coil. If none, replace the pickup solenoid.
	Poor contact of the pickup solenoid connector terminals.	Reinsert the connector. Also check for continuity within the connector cable. If none, remedy or replace the cable.
	Defective finisher main PCB.	Check if CN4-7 on the finisher main PCB goes low. If not, replace the finisher main PCB.
(4) The front side registration motor does not operate.	Broken front side registration motor coil.	Check for continuity across the coil. If none, replace the front side registration motor.
	Poor contact of the front side registration motor connector terminals.	Reinsert the connector. Also check for continuity within the connector cable. If none, remedy or replace the cable.
	Defective finisher main PCB.	Check if a motor drive coil energization signal is output at CN5-1, CN5-3, CN5-4 and CN5-5 on the finisher main PCB. If not, replace the finisher main PCB.
(5) The rear side registration motor does not operate.	Broken rear side registration motor coil.	Check for continuity across the coil. If none, replace the rear side registration motor.
	Poor contact of the rear side registration motor connector terminals.	Reinsert the connector. Also check for continuity within the connector cable. If none, remedy or replace the cable.
	Defective finisher main PCB.	Check if a motor drive coil energization signal is output at CN5-6, CN5-8, CN5-9 and CN5-10 on the finisher main PCB. If not, replace the finisher main PCB.
(6) The trailing edge registration motor does not operate.	Broken trailing edge registration motor coil.	Check for continuity across the coil. If none, replace the trailing edge registration motor.
	Poor contact of the trailing edge registration motor connector terminals.	Reinsert the connector. Also check for continuity within the connector cable. If none, remedy or replace the cable.
	Defective finisher main PCB.	Check if a motor drive coil energization signal is output at CN6-1, CN6-2, CN6-3 and CN6-4 on the finisher main PCB. If not, replace the finisher main PCB.

Problem	Causes	Check procedures/corrective measures
(7) The cooling fan motor does not operate.	Broken cooling fan motor coil.	Check for continuity across the coil. If none, replace the cooling fan motor.
	Poor contact of the cooling fan motor connector terminals.	Reinsert the connector. Also check for continuity within the connector cable. If none, remedy or replace the cable.
	Defective finisher main PCB.	Check if CN4-6 on the finisher main PCB goes low. If not, replace the finisher main PCB.

1-3-4 Mechanical problems

Problem	Causes/check procedures	Corrective measures
(1) Paper jams.	Check if the contact between the feedshift roller and feedshift pulley is correct.	Check and remedy.
	Check if the contact between the feedshift roller and press roller is correct.	Check and remedy.
	Check if the contact between the eject roller and eject pulley is correct.	Check and remedy.
(2) Abnormal noise is heard.	Check if the rollers and gears operate smoothly.	Grease the bushings and gears.

1-4-1 Precautions for assembly and disassembly

(1) Precautions

- Be sure to turn the main switch off and disconnect the power plug before starting disassembly.
- When handling PCBs, do not touch connectors with bare hands or damage the board.
- Do not touch any PCB containing ICs with bare hands or any object prone to static charge.
- Use the following testers when measuring voltages:

Hioki 3200

Sanwa MD-180C

Sanwa YX-360TR

Beckman TECH300

Beckman DM45

Beckman 330*

Beckman 3030*

Beckman DM850*

Fluke 8060A*

Arlec DMM1050

Arlec YF1030C

* Capable of measuring RMS values.

- Prepare the following as test originals:

1. NTC (new test chart)
2. NPTC (newspaper test chart)

(2) Adjusting the positions of the front side registration cursor, rear side registration cursor and trailing edge registration cursor (reference)

Perform the following adjustment if paper registration is poor or stapling is made outside the specified area.

Procedure

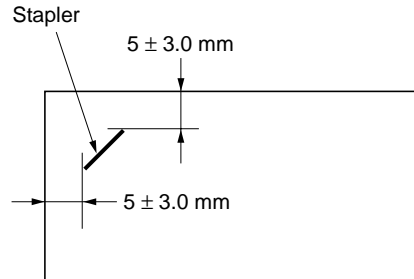
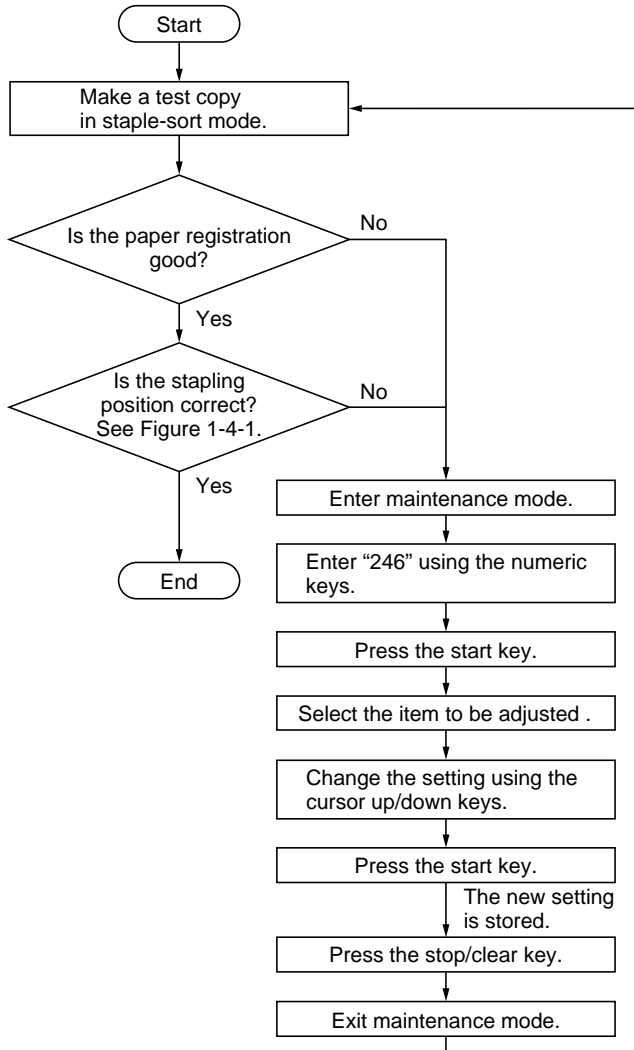

Figure 1-4-1 Stapling position

ADJUST FRONT JOGGER: Stop position of the front side registration cursor
ADJUST REAR JOGGER: Stop position of the rear side registration cursor
ADJUST END JOGGER: Stop position of the trailing edge registration cursor

Setting range: 0 to 8
Reference: 4
Changing the value by 1 changes the position by 0.5 mm.
Increasing the value moves the front or rear side registration cursor or trailing edge registration cursor outward (➡); decreasing the value moves each cursor inward (⇐). See Figure 1-4-2.

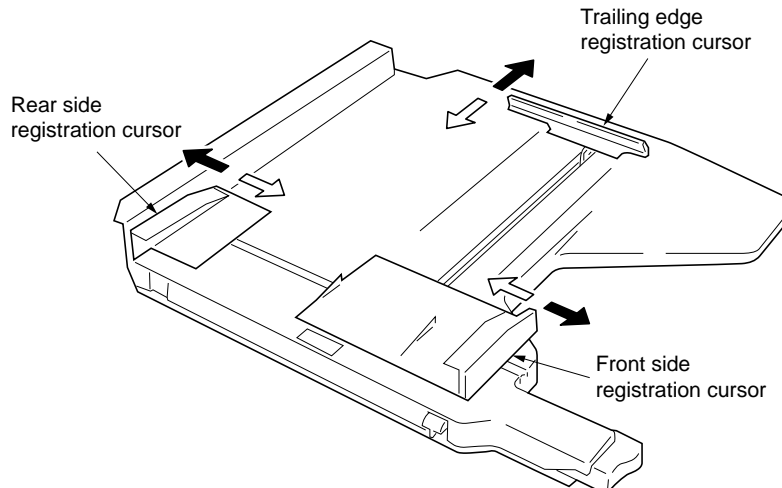

Figure 1-4-2

(3) Cleaning the stapler

During periodic maintenance, remove all the staples remaining inside the machine due to failure of stapling.

Procedure

1. Open the front and conveying covers of the copier.
2. Remove the staple cartridge.
3. Remove the four screws securing the stapler cover and then the cover.
4. Remove the staples attracted to the magnet on the inside of the stapler cover.
5. Refit all the removed parts.

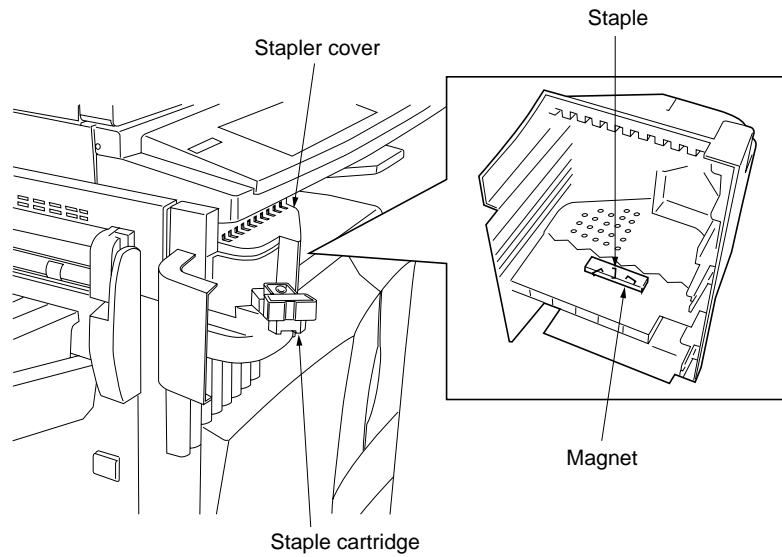

Figure 1-4-3

(4) Adjusting the pressure of curl eliminator mechanism

Increase the pressure of the curl eliminator mechanism to reduce upward curling of paper stacked on the intermediate tray if a paper jam occurs when batch ejection is performed because of strong upward curling.

Procedure

1. Remove the paper conveying unit from the copier.
2. Loosen the two screws from the front and rear curl eliminator pressure adjusting plates respectively and then remove the plates.
3. Refit the all removed parts.

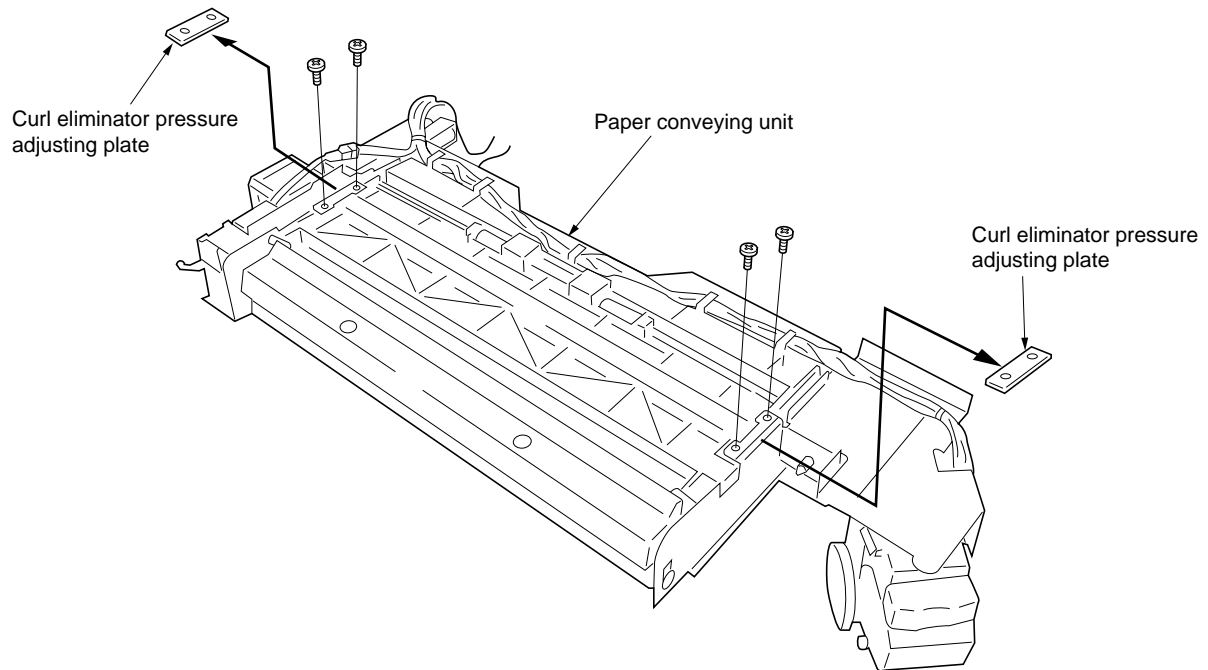

Figure 1-4-4

2-1-1 Construction of each section

The paper conveying section consists of the components shown in Figure 2-1-1. It switches the path for the paper conveyed from the copier in sort mode. Also the paper conveying section contains a curl eliminator mechanism, which reduces curling of paper with curl eliminator rollers.

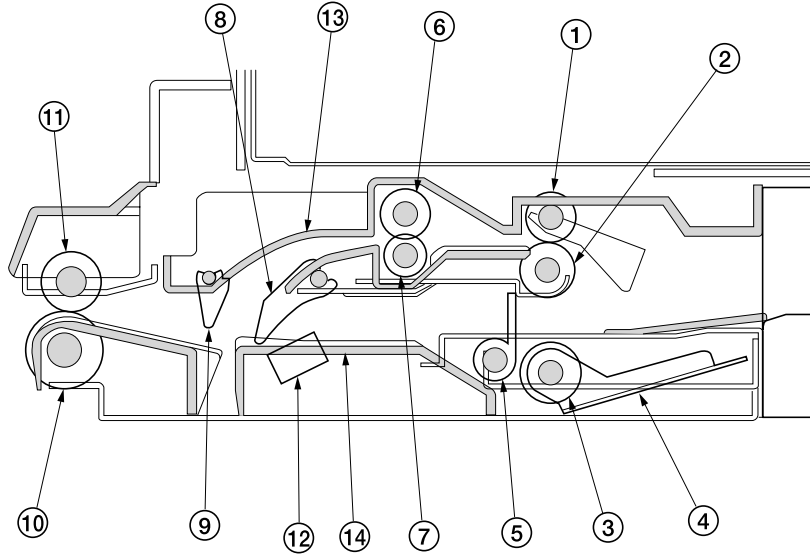

Figure 2-1-1 Paper conveying section

- | | |
|--------------------------------|---------------------------------|
| ① Feedshift pulley | ⑧ Feedshift claw |
| ② Feedshift roller | ⑨ Small feedshift claw |
| ③ Press roller | ⑩ Eject roller |
| ④ Press roller lift | ⑪ Eject pulley |
| ⑤ Stopper | ⑫ Paper conveying switch (PCSW) |
| ⑥ Upper curl eliminator roller | ⑬ Upper guide plate |
| ⑦ Lower curl eliminator roller | ⑭ Lower guide plate |

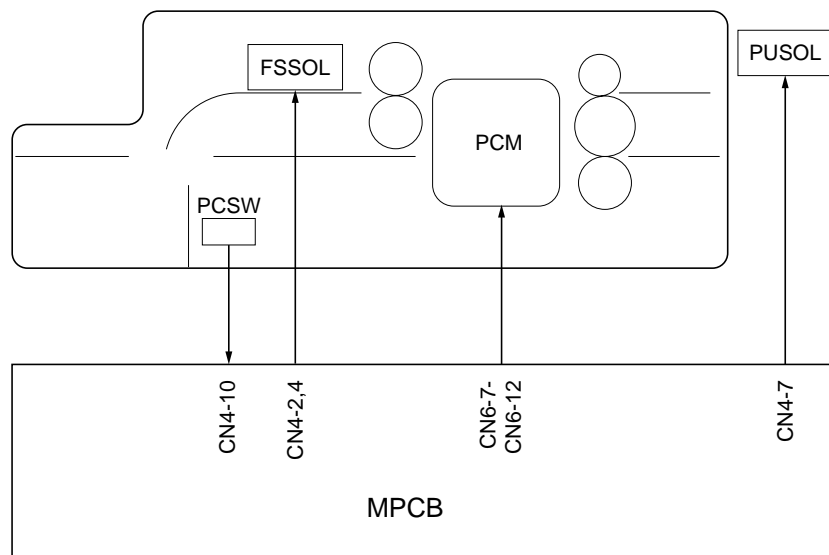

Figure 2-1-2 Paper conveying section block diagram

(1) Paper conveying operation in sort mode

When a copy is made in the sort mode, the feedshift solenoid (FSSOL) turns on and the feedshift guide of the copier operates to switch the paper path to the paper conveying unit. After curling of the conveyed paper is eliminated by the curl eliminator rollers, the paper is conveyed to the intermediate tray by the feedshift roller. When the trailing edge registration cursor of the intermediate tray shifts the paper stocked in the intermediate tray to the stopper, the pickup solenoid (PUSOL) turns on to lift the press roller and release the stopper. The stack of paper on the intermediate tray is ejected to the eject tray by the feedshift roller and eject roller.

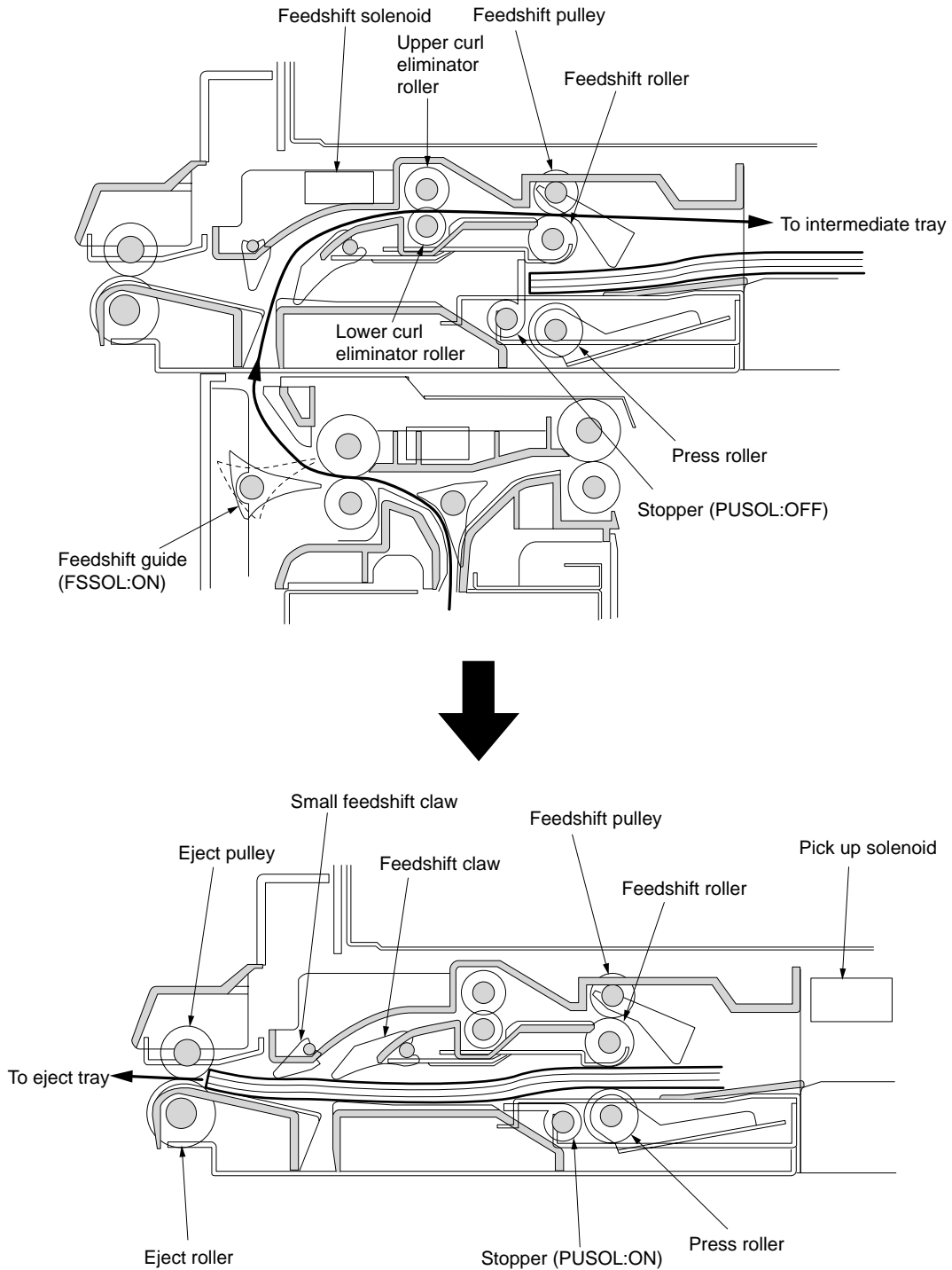

Figure 2-1-3

2-1-2 Intermediate tray section

The intermediate tray section consists of the components shown in Figure 2-1-4. It stores and evens up the paper conveyed from the paper conveying section and returns the stack of paper to the paper conveying section.

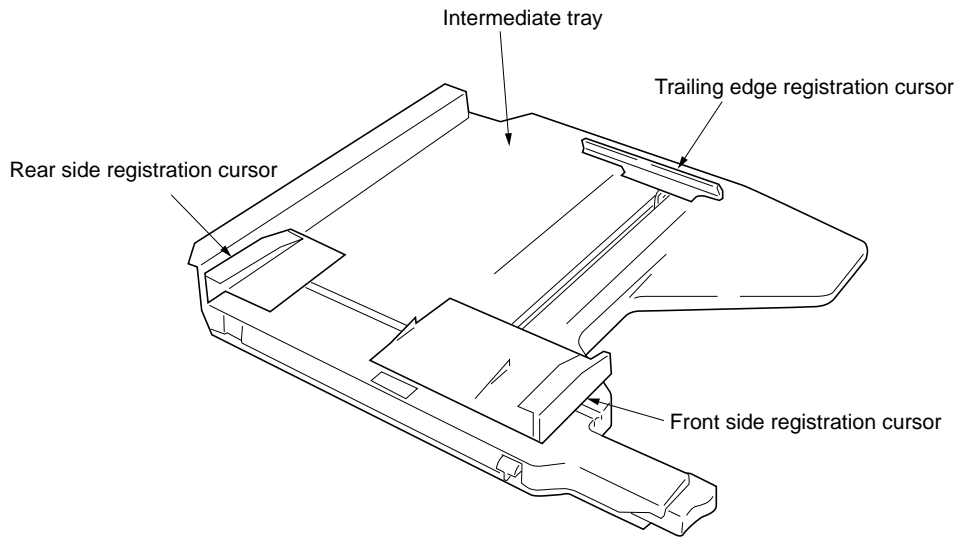

Figure 2-1-4 Intermediate tray section

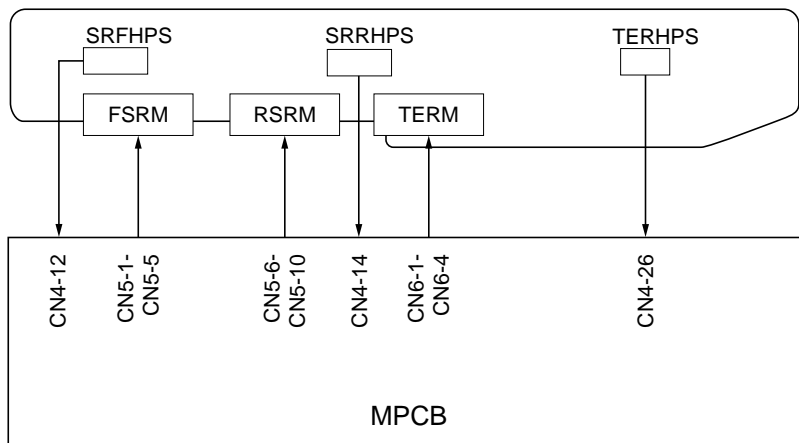

Figure 2-1-5 Intermediate tray section block diagram

(1) Paper registration on the intermediate tray

In sort mode, the front and rear side registration cursors move to the size of the paper used to even up the sides of the stack of paper and the trailing edge registration cursor shifts the paper to the paper conveying section.

In staple-sort mode, the front and rear side registration cursors even up the sides of the stack of paper and shift the stack toward the machine front, and then the trailing edge registration cursor shifts the stack to the stapling position.

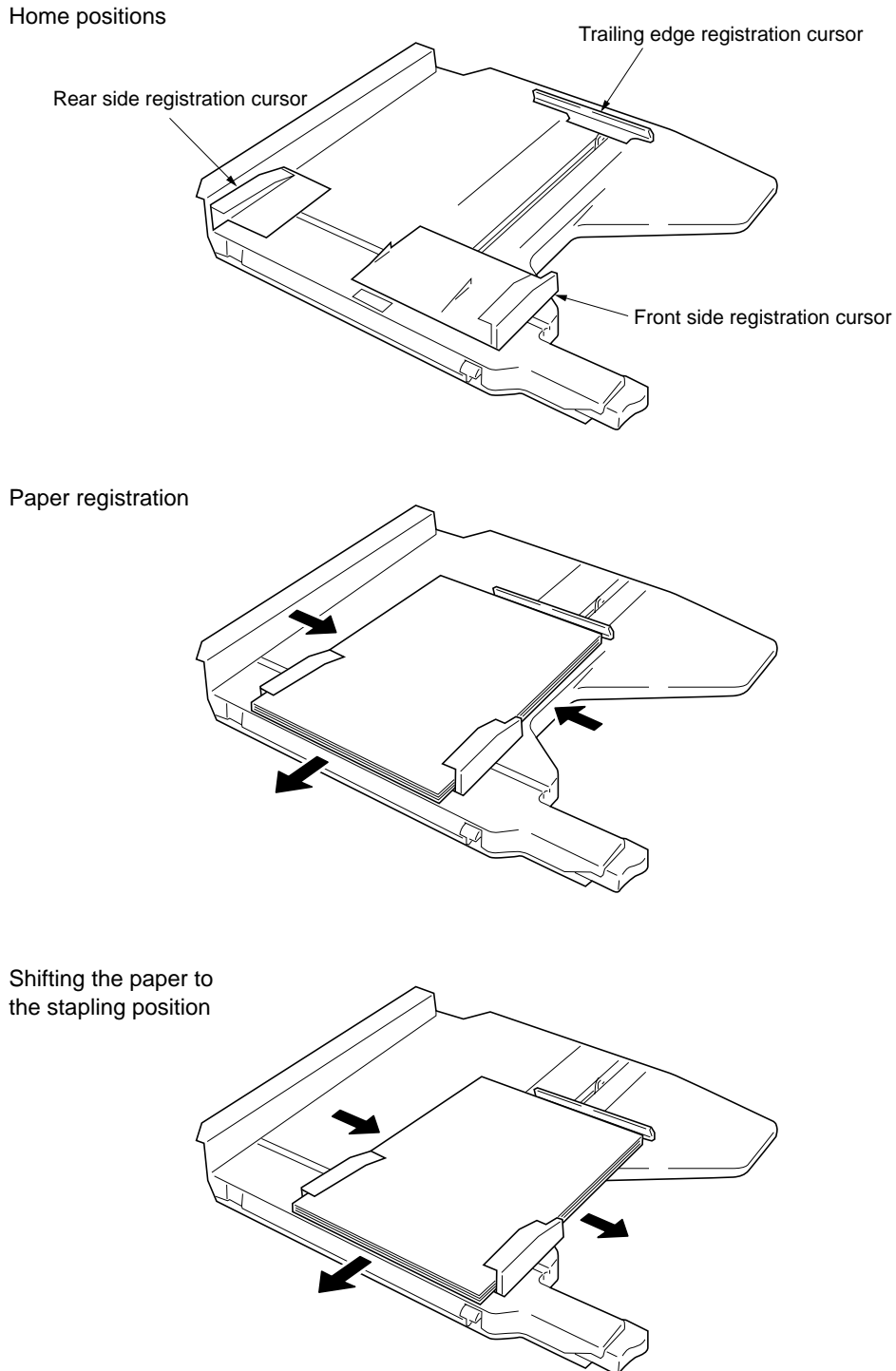

Figure 2-1-6

2-1-3 Stapler section

In staple-sort mode, paper stocked on the intermediate tray is stapled by the stapler. The stapler motor (STM) drives the stapler cam via the stapler drive gear to staple paper.

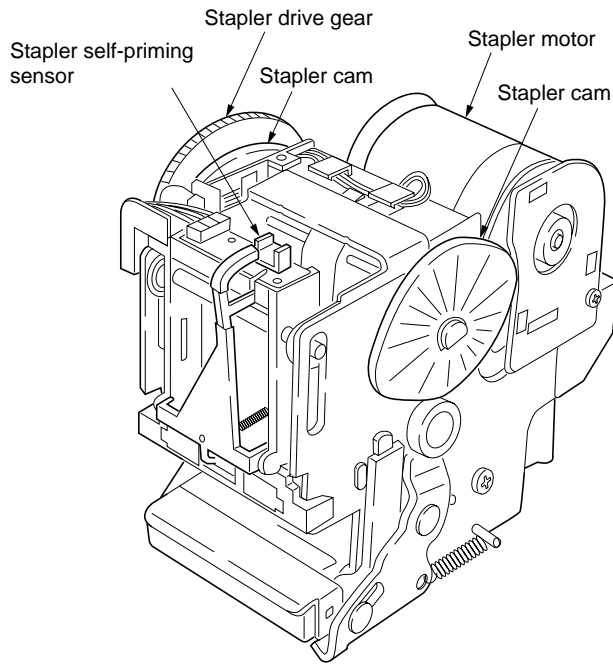

Figure 2-1-7 Stapler section

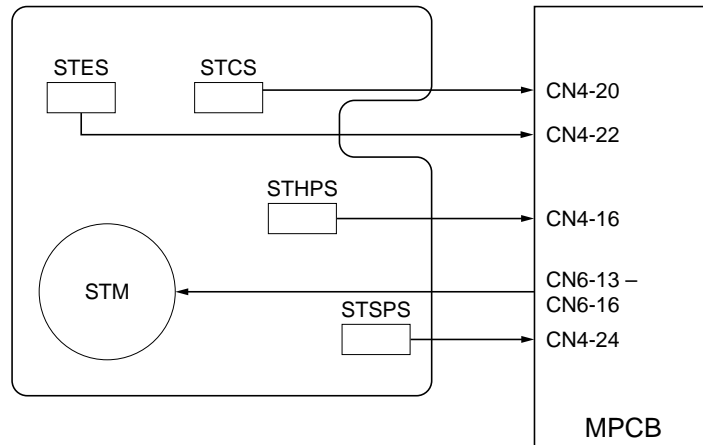

Figure 2-1-8 Stapler section block diagram

2-2-1 Electrical parts layout

(1) Paper conveying section

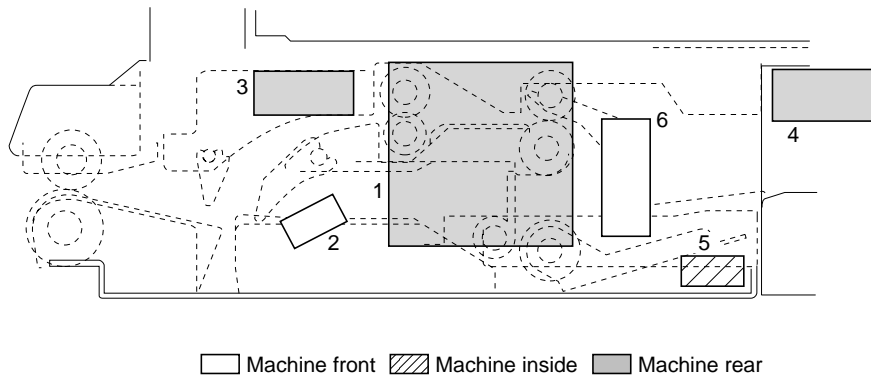

Figure 2-2-1 Paper conveying section

- 1. Paper conveying motor (PCM) Drives the paper conveying section.
- 2. Paper conveying switch (PCSW) Detects a paper jam in the finisher.
- 3. Feedshift solenoid (FSSOL) Operates the feedshift guide of the copier.
- 4. Pickup solenoid (PUSOL) Operates the press roller.
- 5. Tray open/close switch (TOCSW) Detects if the intermediate tray is opened or closed.
- 6. Cooling fan motor (CFM) Cools the stapler section.

(2) Intermediate tray section

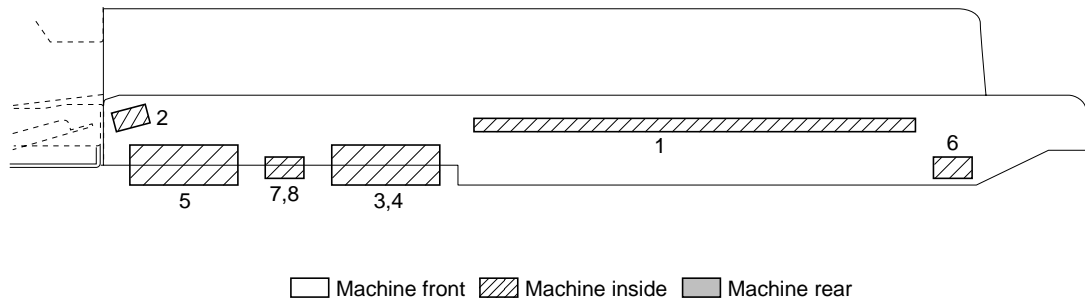

Figure 2-2-2 Intermediate tray section

- 1. Main PCB (MPCB) Controls electrical components.
- 2. Intermediate tray sensor (ITS) Detects the presence of paper on the intermediate tray.
- 3. Trailing edge registration motor (TERM) Drives the trailing edge registration cursor.
- 4. Front side registration motor (FSRM) Drives the front side registration cursor.
- 5. Rear side registration motor (RSRM) Drives the rear side registration cursor.
- 6. Trailing edge registration home position sensor (TERHPS) Detects the trailing edge registration cursor in the home position.
- 7. Side registration front home position sensor (SRFHPS) Detects the front side registration cursor in the home position.
- 8. Side registration rear home position sensor (SRRHPS) Detects the rear side registration cursor in the home position.

(3) Stapler section

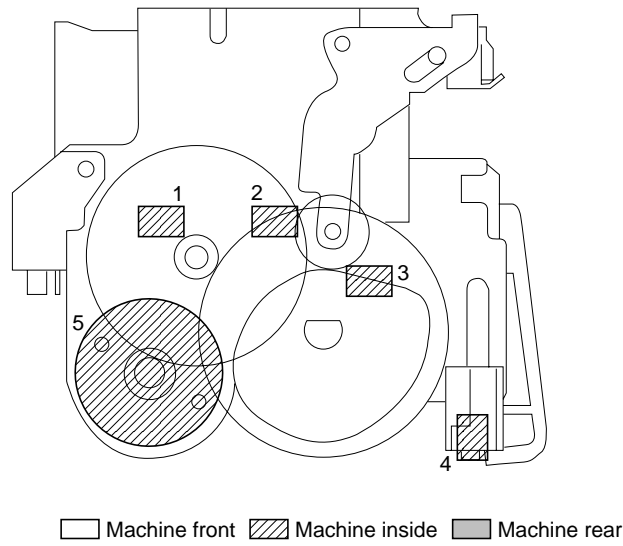

Figure 2-2-3 Stapler section

- 1. Stapler empty sensor (STES) Detects the presence of staples.
- 2. Staple cartridge sensor (STCS) Detects the presence of the staple cartridge.
- 3. Stapler home position sensor (STHPS) Detects the stapler in the home position.
- 4. Stapler self-priming sensor (STSPS) Detects the pre-stapling state of the stapler.
- 5. Stapler motor (STM) Drives the stapler.

2-3-1 Main PCB

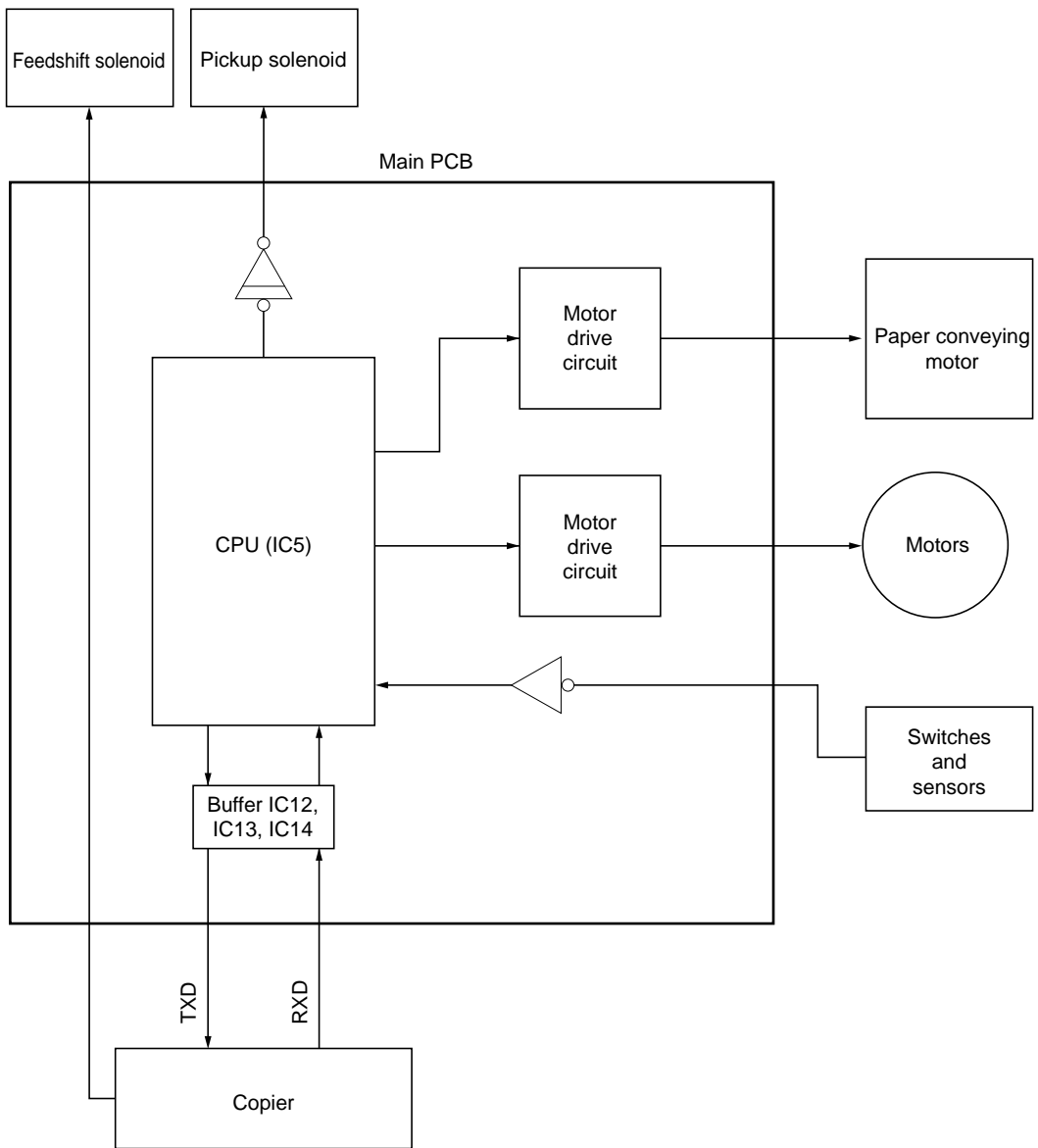

Figure 2-3-1 Main PCB block diagram

The main PCB (MPCB) consists mainly of the CPU IC5 and motor drive circuit. The CPU IC5 detects the condition of the switches and sensors and controls the motors and solenoids by serially communicating with the copier. The feedshift solenoid (FSSOL) operates with the control signals from the copier.

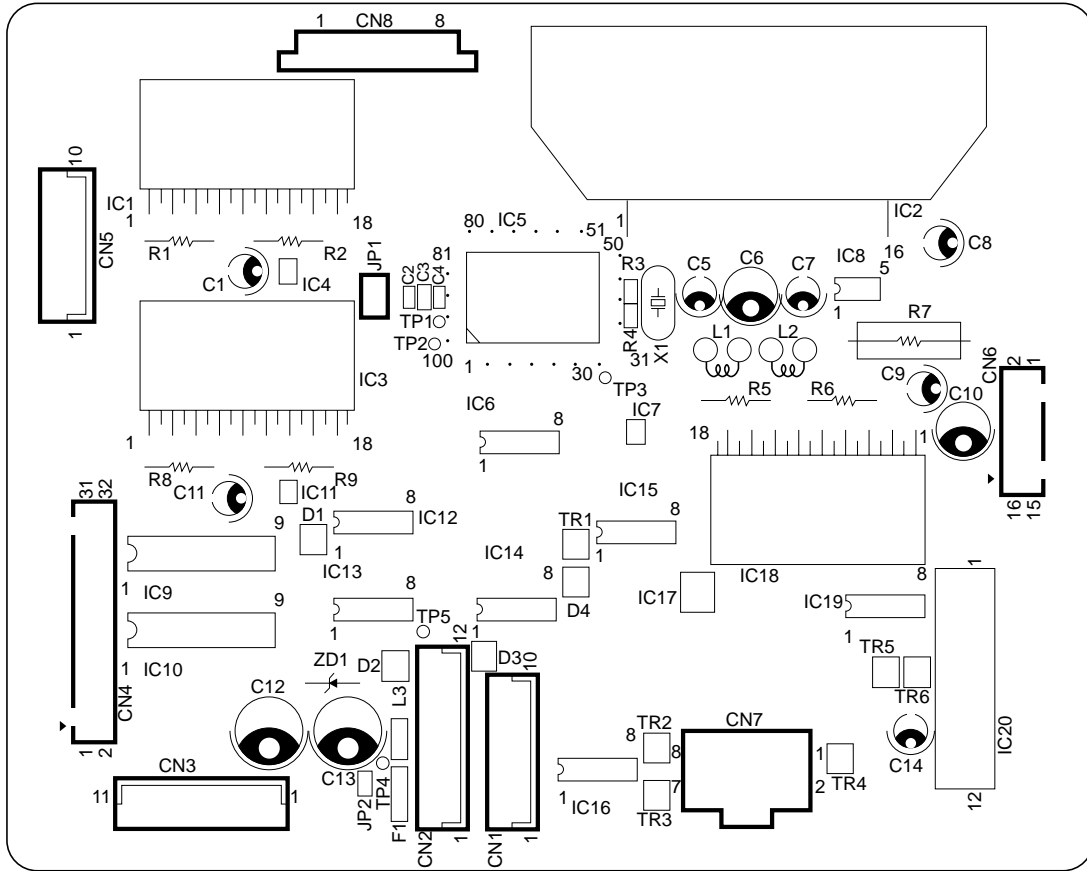
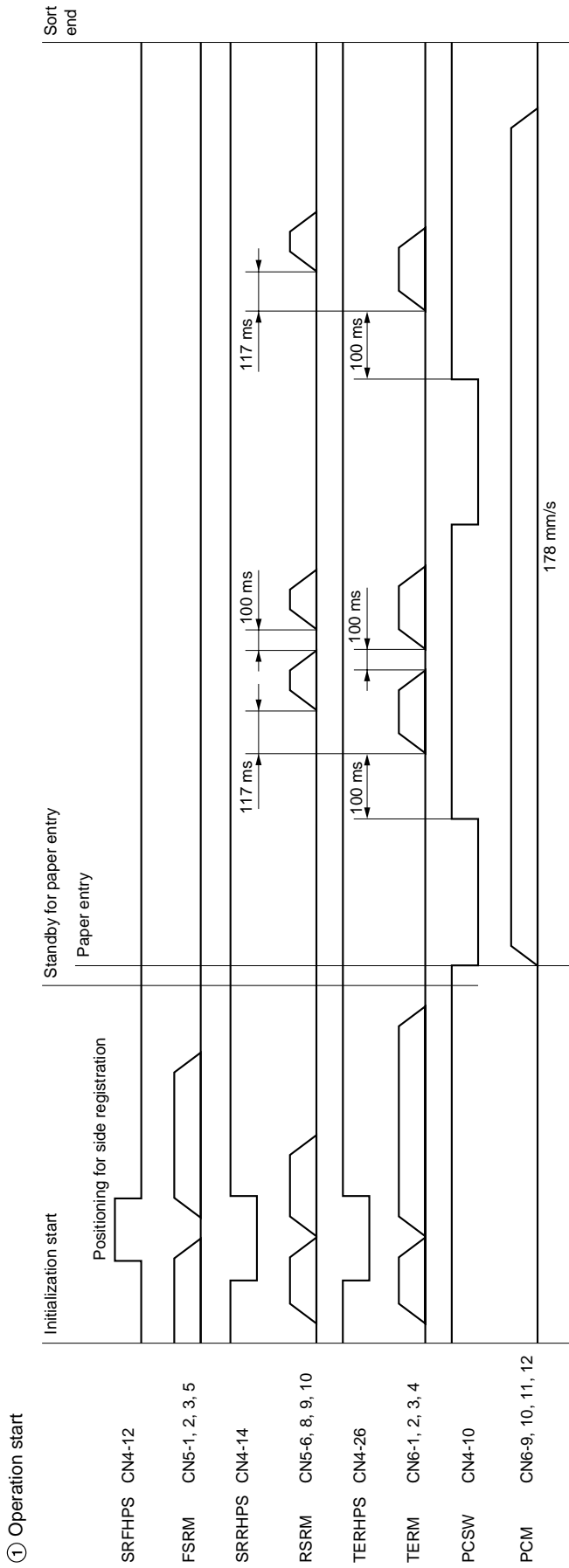

Figure 2-3-2 Main PCB silk-screen diagram

Terminals (CN)		Voltage	Remarks
2-1	2-3	0/5 V DC	RESET signal, input
2-2	2-3	0/5 V DC	Finisher SET signal, input
2-4	2-5	0/5 V DC (pulse)	Serial signal TXD, input
2-6	2-7	0/5 V DC (pulse)	Serial signal RXD, output
2-8	2-7	5 V DC	5 V DC supply, input
2-11	2-9	24 V DC	24 V DC supply, input
2-12	2-10	24 V DC	24 V DC supply, input
3-7	3-4	0/24 V DC	FSSOL release signal, input
3-8	3-4	0/24 V DC	FSSOL latch-on signal, input
3-9	3-4	24 V DC	24 V DC supply for FSSOL, input
4-1	4-29	24 V DC	24 V DC supply for FSSOL, output
4-2	4-29	0/24 V DC	FSSOL latch-on signal, output
4-3	4-29	24 V DC	24 V DC supply for CFM, output
4-4	4-29	0/24 V DC	FSSOL release signal, output
4-5	4-29	24 V DC	24 V DC supply for PUSOL, output
4-6	4-29	0/24 V DC	CFM on/off signal, output
4-7	4-29	0/24 V DC	PUSOL on/off, output
4-9	4-29	5 V DC	5 V DC supply for PCSW, output
4-10	4-29	0/5 V DC	PCSW on/off, input
4-11	4-23	5 V DC	5 V DC supply for SRFHPS, output
4-12	4-23	0/5 V DC	SRFHPS on/off, input
4-13	4-25	5 V DC	5 V DC supply for SRRHPS, output
4-14	4-25	0/5 V DC	SRRHPS on/off, input
4-15	4-27	5 V DC	5 V DC supply for stapler, output
4-16	4-27	0/5 V DC	STHPS on/off, input
4-17	4-21	5 V DC	5 V DC supply for ITS, output
4-18	4-21	0/5 V DC	ITS on/off, input
4-19	4-28	5 V DC	5 V DC supply for TERHPS, output
4-20	4-27	0/5 V DC	STCS on/off, input
4-22	4-27	0/5 V DC	STES on/off, input
4-24	4-27	0/5 V DC	STSPS on/off, input
4-26	4-28	0/5 V DC	TERHPS on/off, input
5-1	2-9	0/24 V DC (pulse)	FSRM motor coil energization pulse, output (A)
5-2	2-9	24 V DC	24 V DC supply for FSRM, output
5-3	2-9	0/24 V DC (pulse)	FSRM motor coil energization pulse, output (\bar{B})
5-4	2-9	0/24 V DC (pulse)	FSRM motor coil energization pulse, output (B)
5-5	2-9	0/24 V DC (pulse)	FSRM motor coil energization pulse, output (\bar{A})
5-6	2-9	0/24 V DC (pulse)	RSRM motor coil energization pulse, output (A)
5-7	2-9	24 V DC	24 V DC supply for RSRM, output
5-8	2-9	0/24 V DC (pulse)	RSRM motor coil energization pulse, output (\bar{B})
5-9	2-9	0/24 V DC (pulse)	RSRM motor coil energization pulse, output (B)
5-10	2-9	0/24 V DC (pulse)	RSRM motor coil energization pulse, output (\bar{A})
6-1	2-9	0/24 V DC (pulse)	TERM motor coil energization pulse, output (A)
6-2	2-9	0/24 V DC (pulse)	TERM motor coil energization pulse, output (\bar{B})
6-3	2-9	0/24 V DC (pulse)	TERM motor coil energization pulse, output (B)
6-4	2-9	0/24 V DC (pulse)	TERM motor coil energization pulse, output (\bar{A})
6-5	2-9	24 V DC	24 V DC supply for TERM, output
6-7	2-9	24 V DC	24 V DC supply for PCM, output
6-8	2-9	24 V DC	24 V DC supply for PCM, output
6-9	2-9	0/24 V DC (pulse)	PCM motor coil energization pulse, output (A)
6-10	2-9	0/24 V DC (pulse)	PCM motor coil energization pulse, output (\bar{A})
6-11	2-9	0/24 V DC (pulse)	PCM motor coil energization pulse, output (B)
6-12	2-9	0/24 V DC (pulse)	PCM motor coil energization pulse, output (\bar{B})
6-13	2-9	0/24 V DC	STM forward rotation drive signal (F), output
6-14	2-9	0/24 V DC	STM forward rotation drive signal (F), output
6-15	2-9	0/24 V DC	STM reverse rotation drive signal (R), output
6-16	2-9	0/24 V DC	STM reverse rotation drive signal (R), output

Terminals (CN)		Voltage	Remarks
7-3	2-9	24 V DC	24 V DC supply for LCSW, output
7-6	2-9	24/0 V DC	LCSW on/off, input

Timing chart No. 1



Timing chart No. 2

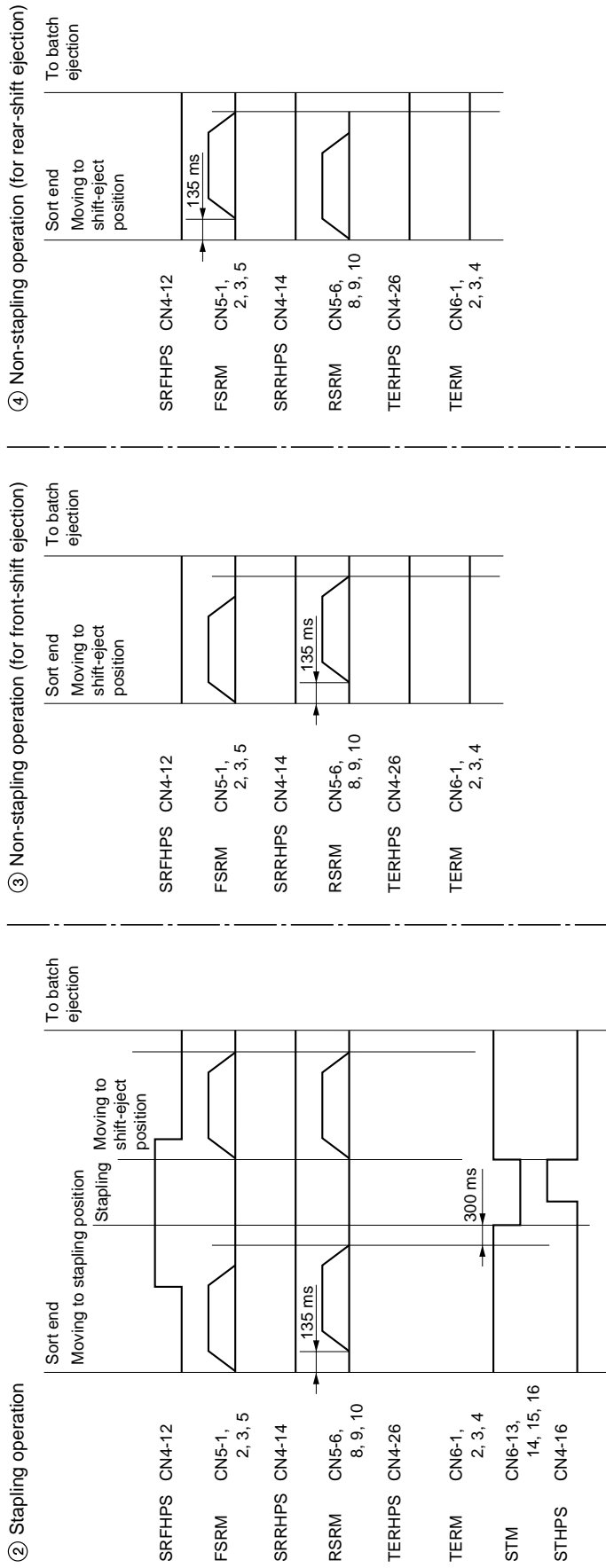

Timing chart No. 3

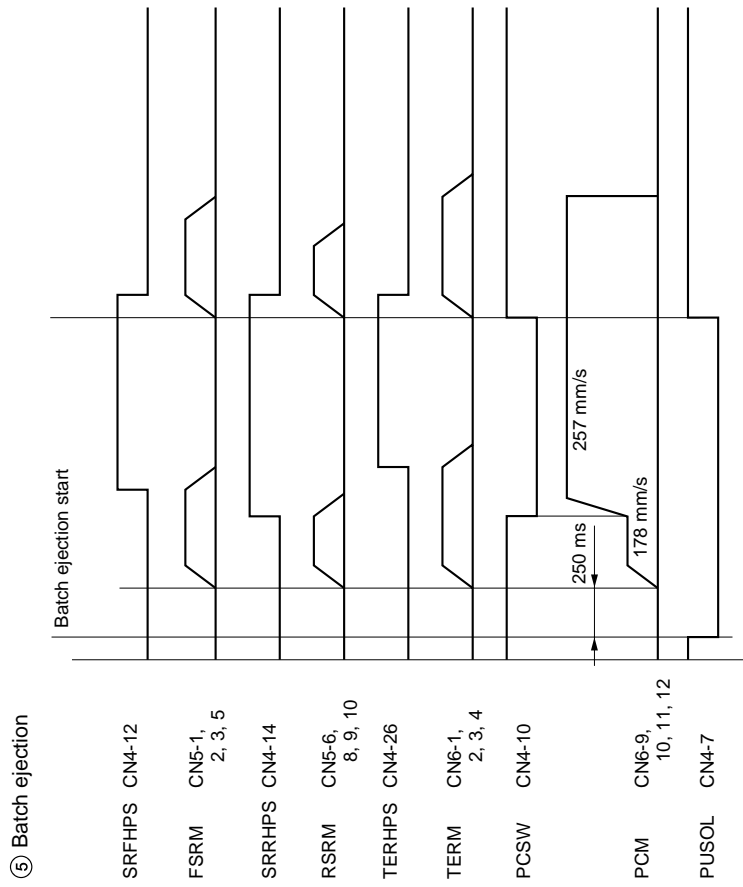

Periodic maintenance procedures

• Finisher

Section	Maintenance part/location	Method	Maintenance cycle	Points and cautions	Page
Stapler section	Magnet	Clean	Every service	Remove the staples attracted to the magnet inside the stapler cover.	1-4-3

Wiring diagram

